



## KEY FEATURES

- Powered two-way line array element
- Compact lightweight moulded enclosure
- WTW driver configuration
- Dual 8" neodymium woofers, 1.4" HF neodymium compression driver
- High quality, low distortion, large format compression driver with titanium diaphragm and new suspension design
- Acoustic filter control for wide and stable 100° horizontal coverage
- Aerodynamic transmission line back loading design resulting in clean mid-bass reproduction, natural cardioid behavior and vented cooling of the amplifier stage
- Natural sounding transmission line HF projection wave-forming device
- 40 bit floating point CORE2 processing with PRONET AX remote control
- Linear phase FIR filters
- Array optimized presets
- Class D amplifier module with SMPS and PFC
- Easy-to-use rigging system

## APPLICATIONS

- Small to medium live sound reinforcement
- Theatre
- Corporate & A/V
- Live music venues
- Delays in larger systems
- Theme parks
- House of Worship
- Leisure and Fitness
- Retail outlets

## TECHNICAL SPECIFICATIONS

### SYSTEM

System's Acoustic Principle	Line Array Element Short Transmission Line LF Back Loading Acoustic Transmission Line HF Waveguide
Frequency Response ( $\pm 3$ dB)	85 Hz – 16.8kHz (Processed)
Horizontal/ Vertical Coverage Angle	100° x 10° (-6dB)
Maximum Peak SPL @ 1m	133.5 dB

### TRANSDUCERS

LF	Two 8" (200mm) neodymium woofers, 2" (38mm) voice coil, 8 $\Omega$ each, paralleled
HF	One 1.4" neodymium driver, 2.5" (64mm) edgewound voice coil, titanium diaphragm, 8 $\Omega$

### ELECTRICAL

Input Impedance	20 k $\Omega$ balanced, 10 k $\Omega$ unbalanced
Input Sensitivity	+4dBu / 1.25 V
Signal Processing	CORE2 processing, 40bit floating point SHARC DSP, 24 bit AD/DA converters
Direct access Controls	4 Presets (Standard/Long Throw/Down Fill-Single Box, User), Network Termination, GND Link
Remote Controls	PRONET AX control software
Network Protocol	CANBUS
Amplifier Type	Class D with SMPS
Output Power	800W + 400W
Mains Voltage Range (Vac)	100 - 240V 50/60Hz with PFC
IN / OUT Connectors	Neutrik XLR-M / XLR-F
IN / OUT Network Connectors	ETHERCON® (NE8FAV)
Mains Connector	PowerCon® (NAC3MPA)
Mains Link Connector	PowerCon® (NAC3MPB)
Cooling	Variable speed DC fan

### ENCLOSURE & CONSTRUCTION

Dimensions (W x H x D)	600 mm (23.6") x 265.5 mm (10.5") x 516 mm (20.3")
Enclosure Material	Polypropylene
Rigging System	
Front Suspension	Aluminum Fast Link structure
Back Suspension	High Strength Steel with ¼ Fast Pin
Net Weight	22.5 Kg (49.6 lbs.)



## DESCRIPTION

The AX800A NEO is a compact lightweight powered line array element that combines superior sound quality with flexibility and ease of use in an organically styled moulded enclosure. It is designed for a wide range of general purpose indoor and outdoor live sound applications and many types of fixed installations. To fully extend low frequency response the AX800A NEO is designed to be used with the complementary SW1800A subwoofer, a compact dual 18" hybrid manifolded bandpass design, in a recommended 4:1 ratio.

## TRANSDUCERS

The high frequency range of the AX800A NEO is reproduced by a low distortion titanium diaphragm compression driver with neodymium magnet and edgewound voice coil, loaded by an acoustic transmission line waveguide providing detailed and natural sounding high frequencies. The exceptionally lightweight high frequency diaphragm benefits from a very low mechanical resonance that is outside of the pass band, and therefore permits the implementation of a relatively low crossover point of 900Hz.

The two 8" neodymium woofers employed in the reproduction of the mid-bass range are equipped with very lightweight cones to ensure fast response at bass and mid-bass frequencies. They are loaded by a new aerodynamic transmission line design that results in clean mid-bass reproduction, natural cardioid behavior, and contributes towards vented cooling of the amplifier stage. The transmission line loading minimizes enclosure resonances and eliminates the "boxy" mid-bass sound commonly obtained from regular bass-reflex enclosures.

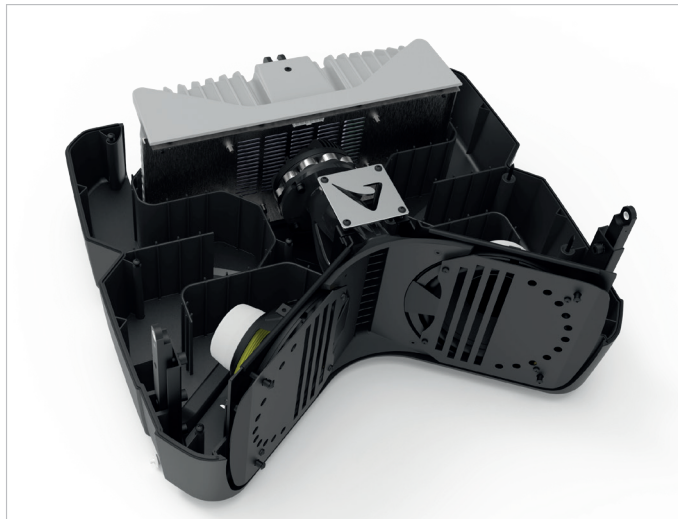

## SYSTEM CONCEPT AND SONIC PERFORMANCE

The AX800A NEO offers a simple but innovative approach to the design of line array elements. The simple concept of the WTW symmetrical drive unit configuration is effectively implemented in order to minimize the effects of potential beaming phenomena arising from the woofers around the crossover frequency.

The orientation and precise separation of the woofers also minimizes interference effects between them, while the use of a mechanical-acoustic polyurethane filter further reduces midrange beaming.

The crossover filter approach is based on a "Constant Power" technique. Thanks to a particular phase combination between the two ways around the crossover frequency, this approach is able to provide a very stable horizontal coverage and a very stable off-axis sound image, also minimizing unwanted effects around the crossover frequency. The further application of phase linearization techniques, combined to constant power crossover, yield a linear phase response and a coherent time response. This allows for a natural perception of acoustic instruments and voices, and for improved depth of the sound image.

## CONSTRUCTION

The two-part AX800A NEO enclosure is manufactured from structurally rigid polypropylene, internally ribbed to entirely eliminate cabinet resonances, and providing the precise transmission line back loading to the two 8" woofers without the need for additional internal panels. This construction results in a very strong, lightweight, and sonically neutral cabinet and allows the rigging hardware to be fully integrated, making it easy to transport and use, as well as offering the benefits of good protection against harsh environmental conditions. The positioning of the amplifier module between the outlets of the two rear ducts provides an additional level of cooling.

## POWER AMPLIFIER

The AX800A NEO is powered by an extremely compact and lightweight CLASS D power amplifier with SMPS and PFC. The innovative technology used for these amplifiers offers top-of-the-range performances, such as a superior sound definition at any audio frequency, very high dynamics even for low level signals, and very low distortion even at maximum power.

The last generation compact PFC power supply with automatic mains voltage selector for world wide operation guarantees reliability and consistency in all operating conditions, with a very high efficiency and low power consumption.

Output power is optimised specifically to the drive units for efficient power transfer, with the low frequency section producing 800 watts while 400 watts is available for the high frequency compression driver. Input and link connections are via balanced 3-pin XLR connectors, and a ground lift switch is provided for hum-free operation. Mains power is connected through a locking Neutrik PowerCON, and a Power Out connector allows mains power to be linked to additional AX800A NEO cabinets.



## SIGNAL PROCESSING

The system processing is based on the new CORE2 DSP platform designed by the PROEL R&D Laboratories using one of the most advanced SHARC DSP devices available for audio applications. It features 40bit, floating point resolution and top-quality 24-bit AD/DA converters for perfect signal integrity, dynamic range in excess of 110dB, and superior sonic performance. Thanks to its massive processing power, the CORE platform is capable of providing the most sophisticated algorithms for speaker processing, including linear phase FIR filters, together with comprehensive remote control and networking capabilities.

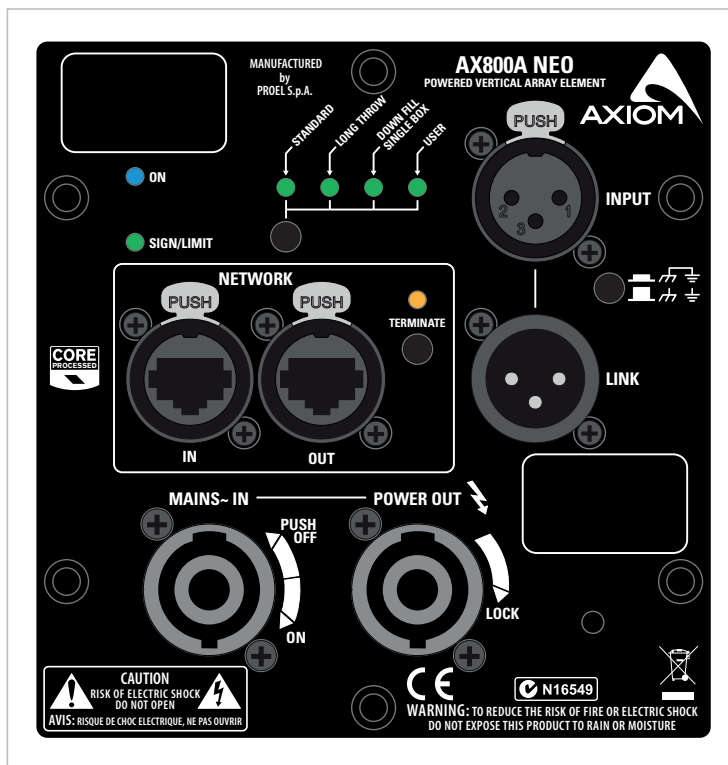

The PRONET AX control software, working on a solid and reliable CANBUS based network protocol, provides an intuitive interface for the remote control of the whole audio system via the rear panel etherCON RJ45 connectors, with the possibility to equalise and delay individual devices, as well as setting driver protection parameters, and monitoring the status of the amplifier.

Four factory DSP presets are provided for when the AX800A NEO cabinets are not connected to a network, and allow for rapid and simple setup: Standard, for general purpose use of arrays up to four cabinets; Long Throw, for longer arrays requiring additional projection over distance; Downfill / Single Box, for near field applications such as stage lip fills and underneath larger line arrays as downfills; and User, allowing custom parameters to be designed in PRONET and recalled for specific situations when off-line.

## RIGGING HARDWARE

The AX800A NEO provides built-in flying hardware as an integral part of the cabinet, offering fast and intuitive rigging from a single flypoint in mobile or fixed applications, together with excellent load-bearing capacity. It consists of a front suspension system constructed from two aluminium fast link structures, which are connected at the top to the KPTAX800 or KPTAX800L flybars with quick release rigging pins, and at the bottom to the next cabinet with quick release rigging pins. The KPTAX800 and KPTAX800L flybars can support respectively a column of up to 4 or 12 cabinets using a single pickup point. Inter-cabinet angles are set by means of the rear cabinet links in increments of 0.5° from 0° to 7.5°. Using the KPAX8 pole adapter up to 2 cabinets can be installed on a speaker pole.

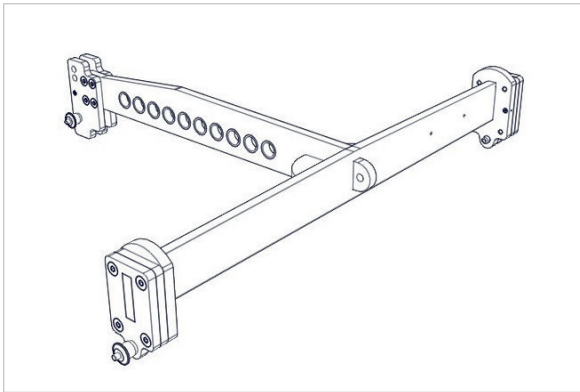

KPTAX800 FLYBAR

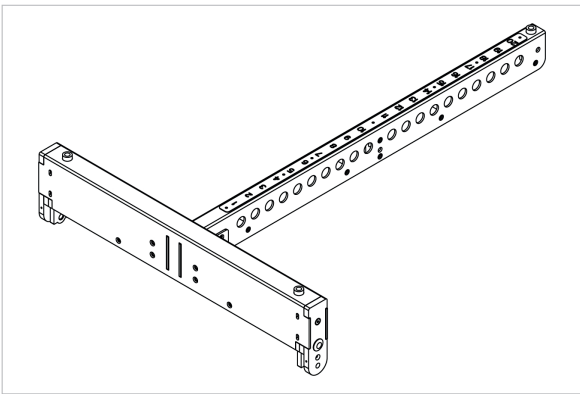

KPTAX800L FLYBAR

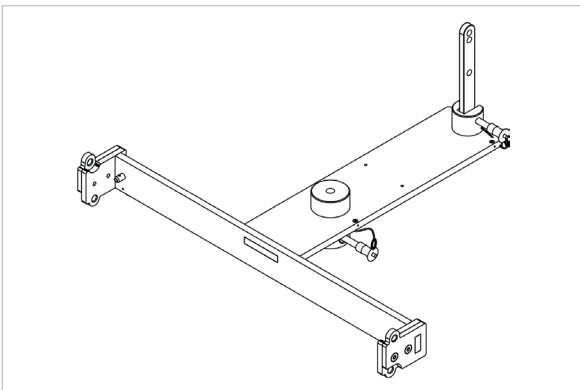

KPTAX8 POLE ADAPTER



## ENGINEERING DRAWING

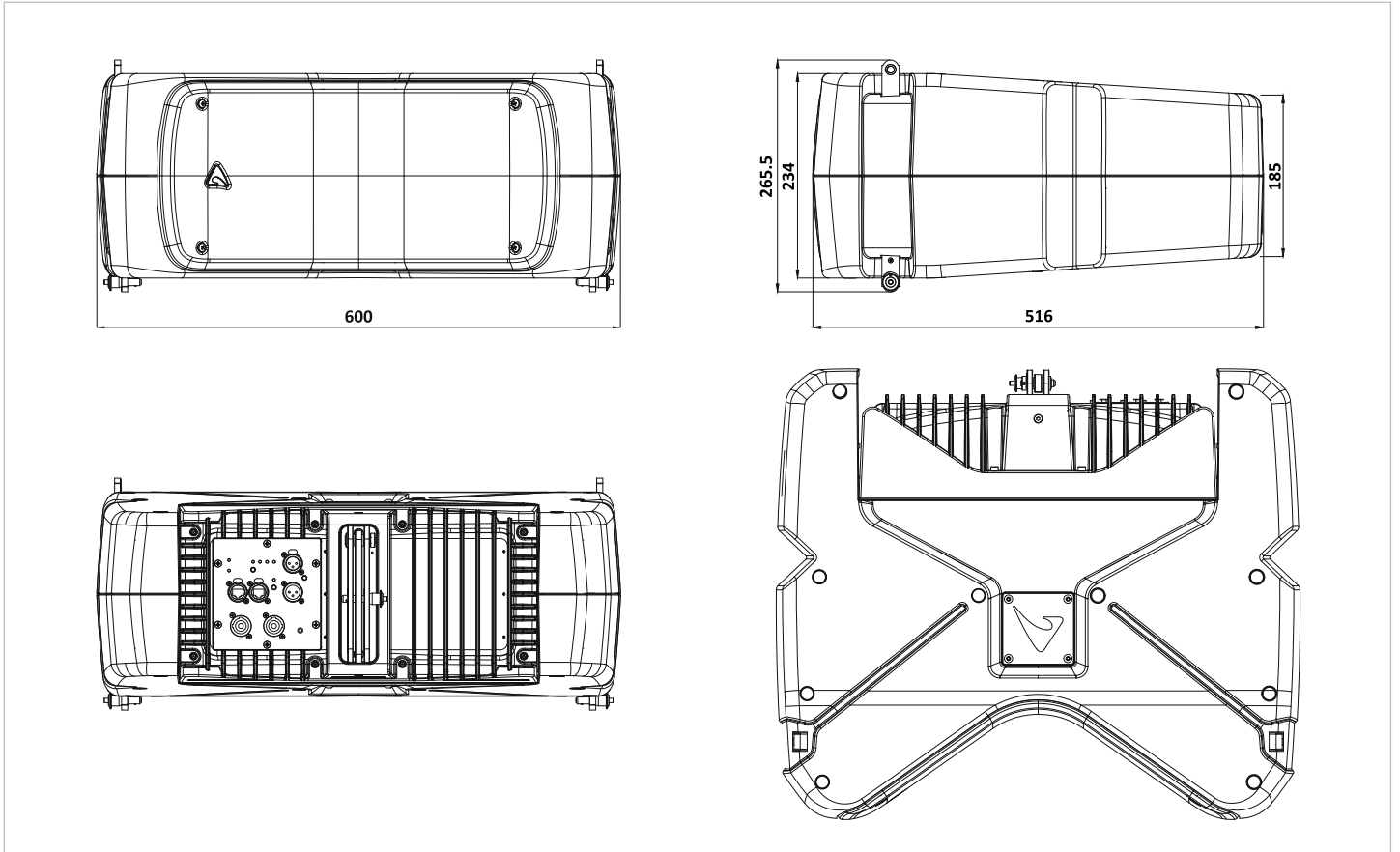

## AX800A NEO frequency response

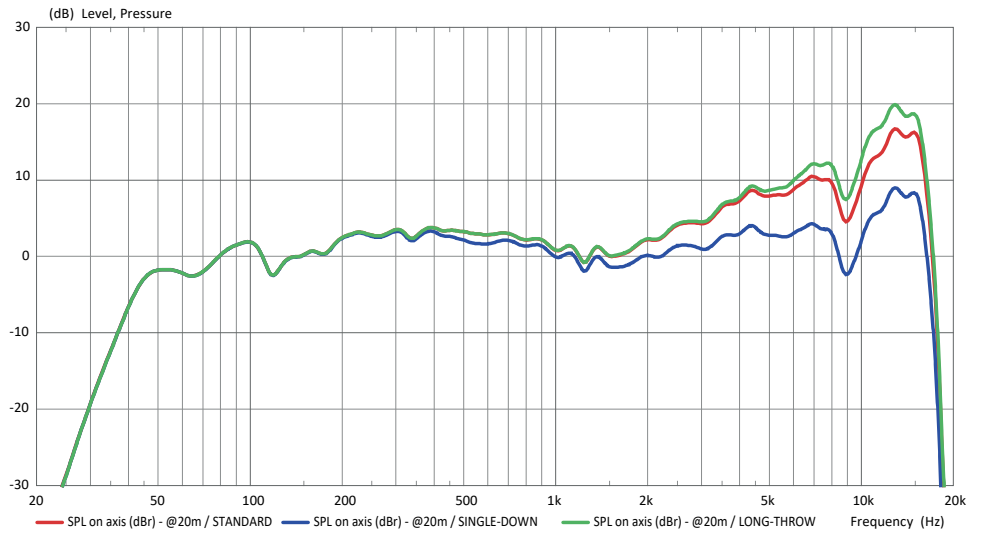

## AX800A NEO HORIZONTAL directivity map

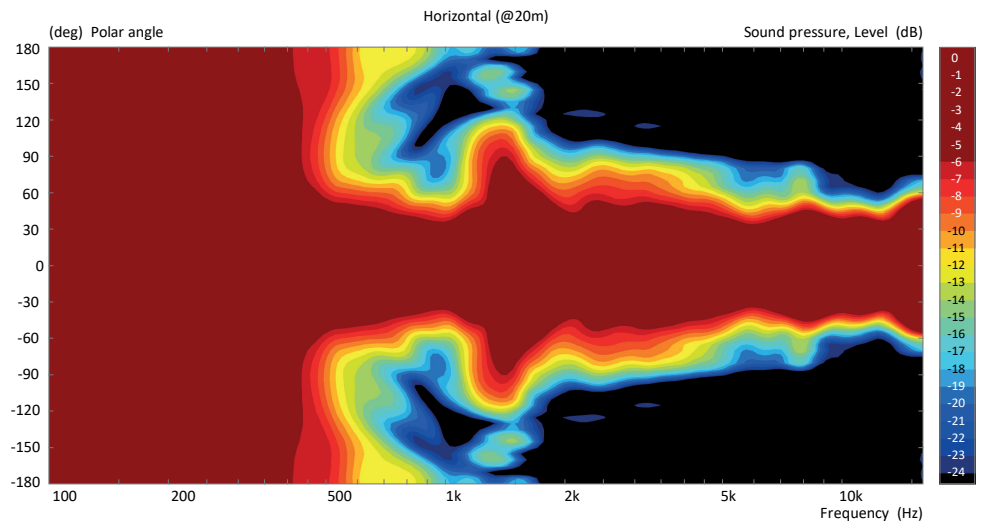

## AX800A NEO VERTICAL directivity map

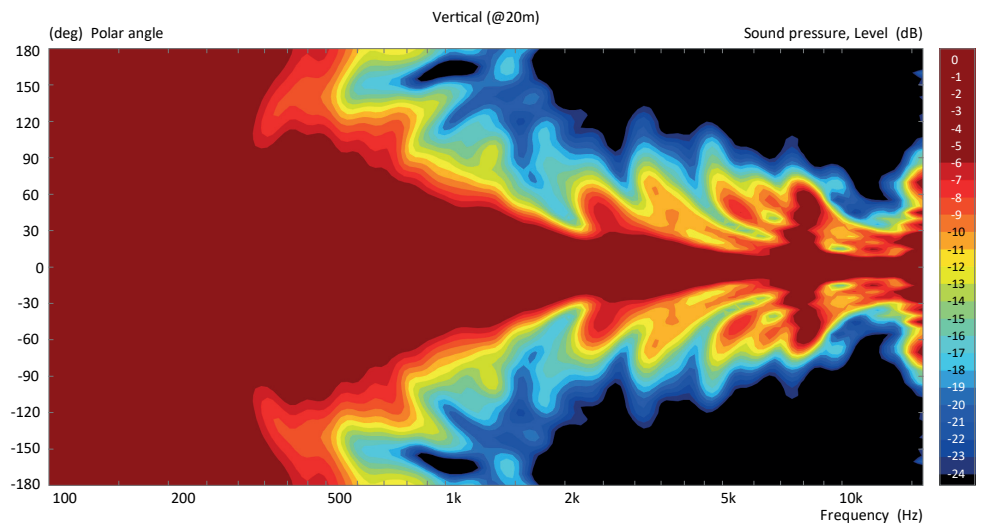

## AX800A NEO HF HORIZONTAL polar diagram

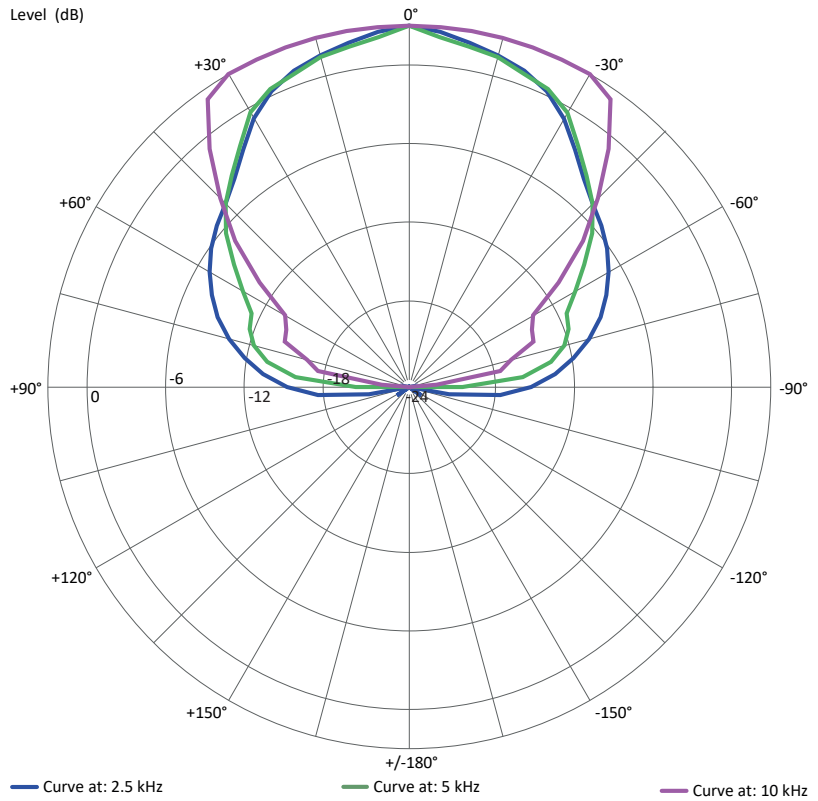

## AX800A NEO HF VERTICAL polar diagram

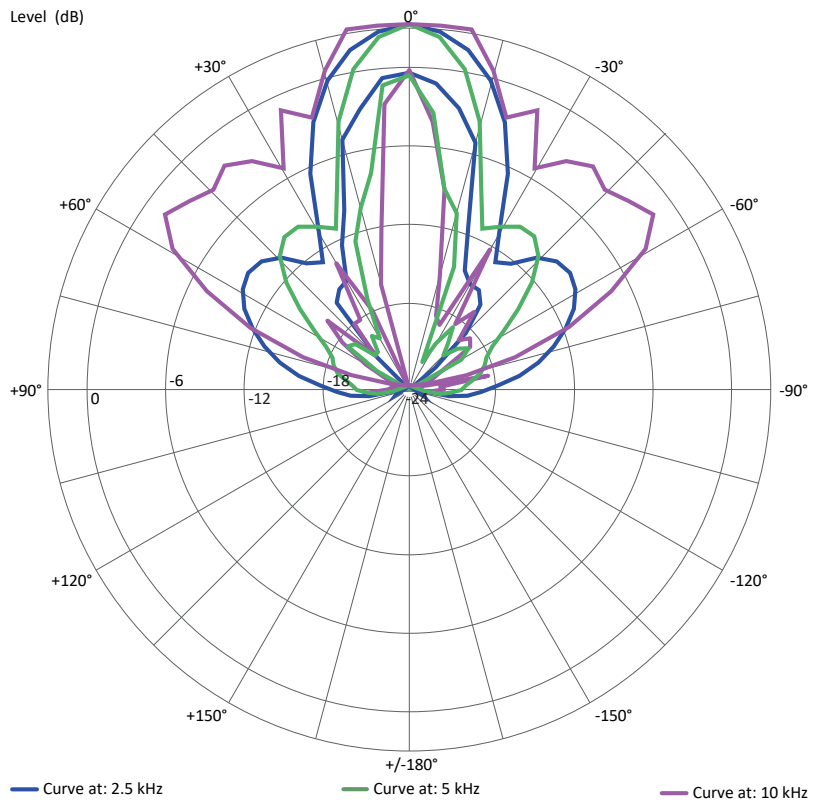

## AX800A NEO LF HORIZONTAL polar diagram

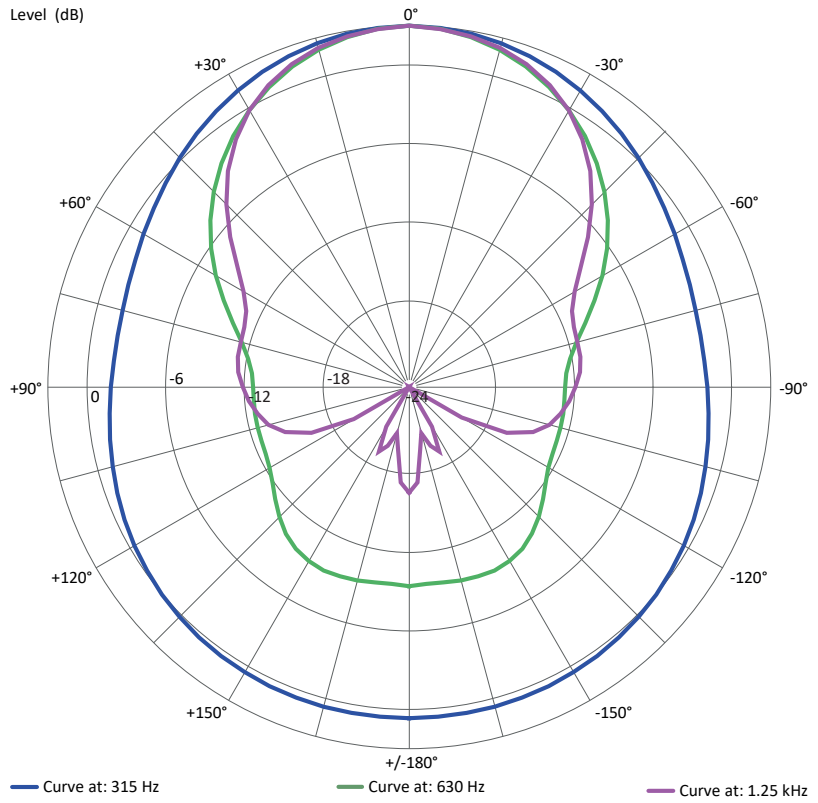

## AX800A NEO LF VERTICAL polar diagram

